



Vertical Captiveyor Z-Frame Conveyor

Product is completely enclosed eliminating spillage and waste

Product Description

- Vertical product transfer conveyor replaces costly bucket elevators
- USDA and FDA approved dual conveyor design allows easy access for sanitation
- Transfers up to 5,000 lbs per hour
- Gentle product transfer reduces breakage
- Interlocking belt design allows unitized product and belt movement



Contact us today to discuss solutions for your project.
sales@psg-dallas.com

Related Products



Mixing Use Tank Skid



Tank Farms, Corn Soak Systems

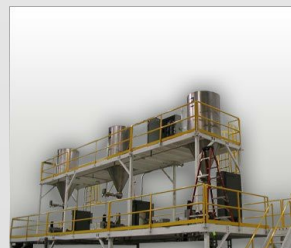

Platforms, Mezzanines & Stairways



Sanitary Process Conveyor

Project Management • Engineers • Fabricators • Installers

Project Services Group • 2040 Century Center Blvd Suite #10 • Irving TX 75062 • (972) 812-7370 • sales@psg-dallas.com